

CDI-4000D INSTRUCTION MANUAL

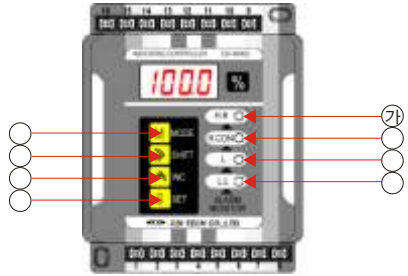

- ⊕ H.H LAMP : H.H ALARM
- H/ CONTROL LAMP : HALARM
START/STOP
- L LAMP : LOW ALARM
- L.L. LAMP : L.L ALARM
- MODE KEY : , RANGE
- SHIFT KEY : PROGRAM
- UP KEY : 가
- ENTER KEY :

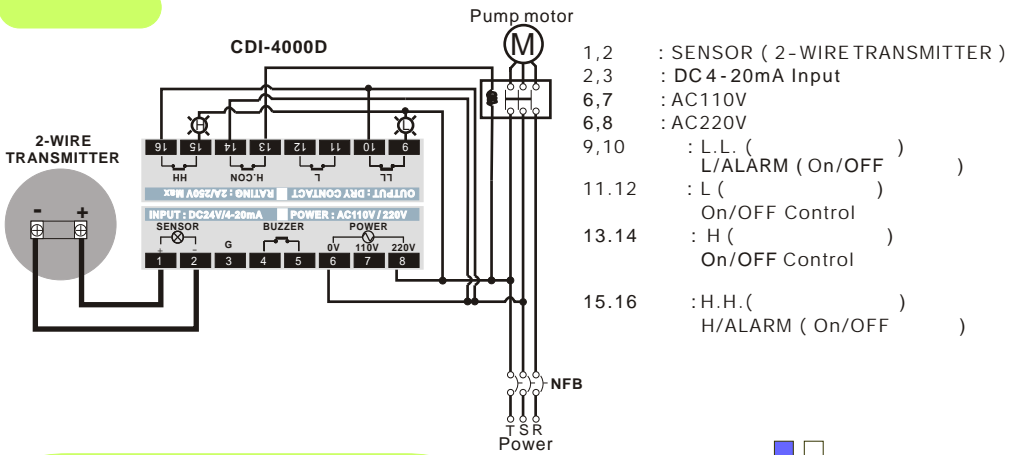

- 1,2 : SENSOR (2-WIRE TRANSMITTER)
- 2,3 : DC 4 - 20mA Input
- 6,7 : AC 110V
- 6,8 : AC 220V
- 9,10 : L.L. ()
- L/ALARM (On/OFF)
- 11,12 : L ()
- On/OFF Control
- 13,14 : H ()
- On/OFF Control
- 15,16 : H.H. ()
- H/ALARM (On/OFF)

(PSE 0-6)

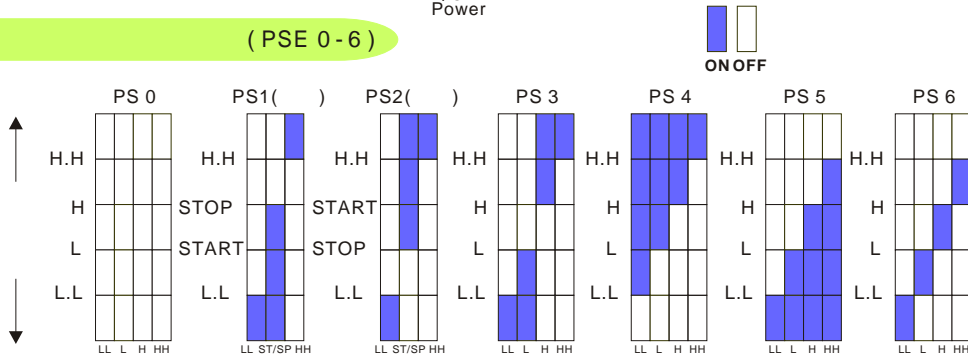

		(SCALE 0-100%)
PS - 1		LL(20) < START(40) < STOP(60) < HH(80)
PS - 2		LL(20) < STOP(40) < START(60) < HH(80)
PS - 3 to PS - 6	ALARM SETTER	LL(20) < L(40) < H(60) < HH(80)
PS - 0	DISPLAY	

